

[IE25H-M-CP]

1.5" Chrome Angle Valve with hydrolator Female NPT Inlet x Male Hose Outlet.



300 lbs (2068 kPa) pressure tested approved valve. Heavy Duty 1-1/2" (38 mm) chrome angle hose and hydrolator valve. Automatically drains and vents, safeguarding against hose deterioration. O-ring packing and red cast handle. Forgeline Bonnet and Seat Assembly. UL/ULC listed and FM Approved. Specify NPSH or NST thread for outlet.

FINISH: Cast Chrome

OPTIONS: Cast Brass, Polish Brass, Polish Chrome



Dimensions:

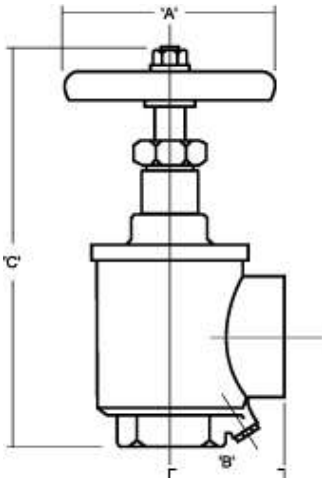

A = 4" (100mm)
B = 2 3/4" (69.85mm)
C = 8" (OPEN) (200mm)
C = 7" (CLOSED) (175mm)

PROJECT	APPROVAL STAMP
PROJECT:	<input type="checkbox"/> APPROVED
ADDRESS:	<input type="checkbox"/> APPROVED AS NOTED
ENGINEER:	<input type="checkbox"/> NOT APPROVED
SUBMITTAL DATA:	REMARKS:
NOTES 1:	
NOTES 2:	